

Business Analysis (P3) June & December 2012

This syllabus and study guide is designed to help with planning study and to provide detailed information on what could be assessed in any examination session.

THE STRUCTURE OF THE SYLLABUS AND STUDY GUIDE

Relational diagram of paper with other papers

This diagram shows direct and indirect links between this paper and other papers preceding or following it. Some papers are directly underpinned by other papers such as Advanced Performance Management by Performance Management. These links are shown as solid line arrows. Other papers only have indirect relationships with each other such as links existing between the accounting and auditing papers. The links between these are shown as dotted line arrows. This diagram indicates where you are expected to have underpinning knowledge and where it would be useful to review previous learning before undertaking study.

Overall aim of the syllabus

This explains briefly the overall objective of the paper and indicates in the broadest sense the capabilities to be developed within the paper.

Main capabilities

This paper's aim is broken down into several main capabilities which divide the syllabus and study guide into discrete sections.

Relational diagram of the main capabilities

This diagram illustrates the flows and links between the main capabilities (sections) of the syllabus and should be used as an aid to planning teaching and learning in a structured way.

Syllabus rationale

This is a narrative explaining how the syllabus is structured and how the main capabilities are linked. The rationale also explains in further detail what the examination intends to assess and why.

Detailed syllabus

This shows the breakdown of the main capabilities (sections) of the syllabus into subject areas. This is the blueprint for the detailed study guide.

Approach to examining the syllabus

This section briefly explains the structure of the examination and how it is assessed.

Study Guide

This is the main document that students, tuition providers and publishers should use as the basis of their studies, instruction and materials. Examinations will be based on the detail of the study guide which comprehensively identifies what could be assessed in any examination session. The study guide is a precise reflection and breakdown of the syllabus. It is divided into sections based on the main capabilities identified in the syllabus. These sections are divided into subject areas which relate to the sub-capabilities included in the detailed syllabus. Subject areas are broken down into sub-headings which describe the detailed outcomes that could be assessed in examinations. These outcomes are described using verbs indicating what exams may require students to demonstrate, and the broad intellectual level at which these may need to be demonstrated (*see intellectual levels below).

Learning Materials

ACCA's Approved Learning Partner - content (ALP-c) is the programme through which ACCA approves learning materials from high quality content providers designed to support study towards ACCA's qualifications.

ACCA has one Platinum Approved Learning Partner content which is BPP Learning Media. In addition, there are a number of Gold Approved Learning Partners - content.

For information about ACCA's Approved Learning Partners - content, please go ACCA's Content Provider Directory.

The Directory also lists materials by Subscribers, these materials have not been quality assured by ACCA but may be helpful if used in conjunction with approved learning materials. You will also find details of Examiner suggested Additional Reading which may be a useful supplement to approved learning materials.

ACCA's Content Provider Directory can be found here – http://www.accaglobal.com/learningproviders/alpc/content_provider_directory/search/.

Relevant articles will also be published in Student Accountant.

INTELLECTUAL LEVELS

The syllabus is designed to progressively broaden and deepen the knowledge, skills and professional values demonstrated by the student on their way through the qualification.

The specific capabilities within the detailed syllabuses and study guides are assessed at one of three intellectual or cognitive levels:

Level 1: Knowledge and comprehension

Level 2: Application and analysis

Level 3: Synthesis and evaluation

Very broadly, these intellectual levels relate to the three cognitive levels at which the Knowledge module, the Skills module and the Professional level are assessed.

Each subject area in the detailed study guide included in this document is given a 1, 2, or 3 superscript, denoting intellectual level, marked at the end of each relevant line. This gives an indication of the intellectual depth at which an area could be assessed within the examination. However, while level 1 broadly equates with the Knowledge module, level 2 equates to the Skills module and level 3 to the Professional level, some lower level skills can continue to be assessed as the student progresses through each module and level. This reflects that at each stage of study there will be a requirement to broaden, as well as deepen

capabilities. It is also possible that occasionally some higher level capabilities may be assessed at lower levels.

LEARNING HOURS

The ACCA qualification does not prescribe or recommend any particular number of learning hours for examinations because study and learning patterns and styles vary greatly between people and organisations. This also recognises the wide diversity of personal, professional and educational circumstances in which ACCA students find themselves.

Each syllabus contains between 23 and 35 main subject area headings depending on the nature of the subject and how these areas have been broken down.

GUIDE TO EXAM STRUCTURE

The structure of examinations varies within and between modules and levels.

The Fundamentals level examinations contain 100% compulsory questions to encourage candidates to study across the breadth of each syllabus.

The Knowledge module is assessed by equivalent two-hour paper based and computer based examinations.

The Skills module examinations are all paper based three-hour papers. The structure of papers varies from ten questions in the *Corporate and Business Law* (F4) paper to four 25 mark questions in *Financial Management* (F9). Individual questions within all Skills module papers will attract between 10 and 30 marks.

The Professional level papers are all three-hour paper based examinations, all containing two sections. Section A is compulsory, but there will be some choice offered in Section B.

For all three hour examination papers, ACCA has introduced 15 minutes reading and planning time.

This additional time is allowed at the beginning of each three-hour examination to allow candidates to read the questions and to begin planning their

answers before they start writing in their answer books. This time should be used to ensure that all the information and exam requirements are properly read and understood.

During reading and planning time candidates may only annotate their question paper. They may not write anything in their answer booklets until told to do so by the invigilator.

The Essentials module papers all have a Section A containing a major case study question with all requirements totalling 50 marks relating to this case. Section B gives students a choice of two from three 25 mark questions.

Section A of each of the Options papers contains 50-70 compulsory marks from two questions, each attracting between 25 and 40 marks. Section B will offer a choice of two from three questions totalling 30-50 marks, with each question attracting between 15 and 25 marks.

The pass mark for all ACCA Qualification examination papers is 50%.

GUIDE TO EXAMINATION ASSESSMENT

ACCA reserves the right to examine anything contained within the study guide at any examination session. This includes knowledge, techniques, principles, theories, and concepts as specified.

For the financial accounting, audit and assurance, law and tax papers except where indicated otherwise, ACCA will publish *examinable documents* once a year to indicate exactly what regulations and legislation could potentially be assessed within identified examination sessions..

For paper based examinations regulation **issued** or legislation **passed** on or before 30th September annually, will be assessed from June 1st of the following year to May 31st of the year after. Please refer to the examinable documents for the paper (where relevant) for further information.

Regulation issued or legislation passed in accordance with the above dates may be examinable even if the **effective** date is in the future.

The term issued or passed relates to when regulation or legislation has been formally approved.

The term effective relates to when regulation or legislation must be applied to an entity transactions and business practices.

The study guide offers more detailed guidance on the depth and level at which the examinable documents will be examined. The study guide should therefore be read in conjunction with the examinable documents list.

Syllabus

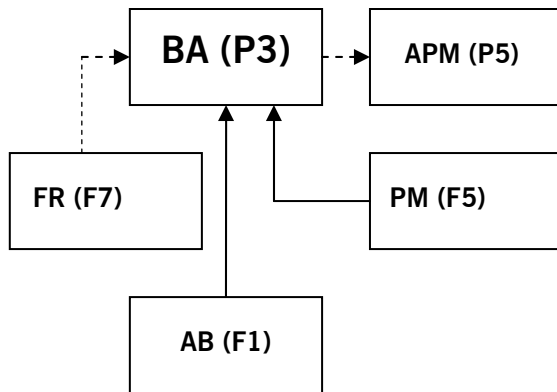

AIM

To apply relevant knowledge, skills, and exercise professional judgement in assessing strategic position, determining strategic choice, and implementing strategic action through beneficial business process and structural change; coordinating knowledge systems and information technology and by effectively managing processes, projects, and people within financial and other resource constraints.

MAIN CAPABILITIES

On successful completion of this paper, candidates should be able to:

- A** Assess the strategic position of an organisation
- B** Evaluate the strategic choices available to an organisation
- C** Discuss how an organisation might go about its strategic implementation
- D** Evaluate and redesign business processes and structures to implement and support the organisation's strategy taking account of customer and other major stakeholder requirements
- E** Integrate appropriate information technology solutions to support the organisation's strategy
- F** Advise on the principles of project management to enable the implementation of aspects of the organisation's strategy with the twin objectives of managing risk and ensuring benefits realisation
- G** Analyse and evaluate the effectiveness of a company's strategy and the financial consequences of implementing strategic decisions
- H** Assess the role of leadership and people management in formulating and implementing business strategy.

RELATIONAL DIAGRAM OF MAIN CAPABILITIES

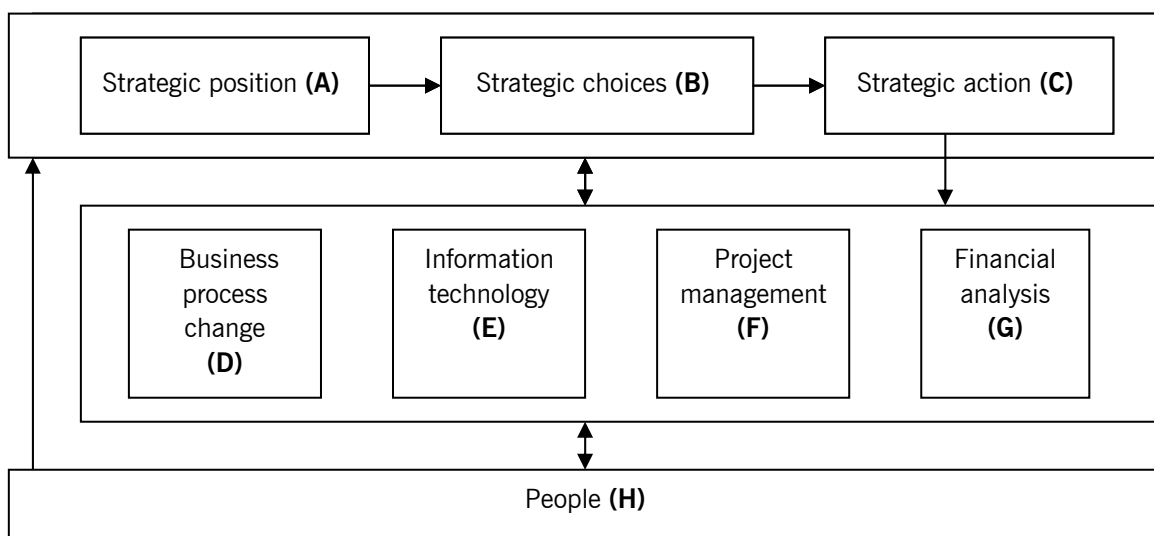

RATIONALE

The syllabus for Paper P3, *Business Analysis*, is primarily concerned with two issues. The first is the external forces (the behaviour of customers, the initiatives of competitors, the emergence of new laws and regulations) that shape the environment of an organisation. The second is the internal ambitions and concerns (desire for growth, the design of processes, the competences of employees, the financial resources) that exist within an organisation. This syllabus looks at both of these perspectives, from assessing strategic position and choice to identifying and formulating strategy and strategic action. It identifies opportunities for beneficial change that involve people, finance and information technology. It examines how these opportunities may be implemented through the appropriate management of programmes and projects.

The syllabus begins with the assessment of strategic position in the present and in the future using relevant forecasting techniques, and is primarily concerned with the impact of the external environment on the business, its internal capabilities and expectations and how the organisation positions itself under these constraints. It examines how factors such as culture, leadership and stakeholder expectations shape organisational purpose. Strategic choice is concerned with decisions which have to be made about an organisation's future and the way in which it can respond to the influences and pressures identified in the assessment of its current and future strategic position.

Strategic action concerns the implementation of strategic choices and the transformation of these choices into organisational action. Such action takes place in day-to-day processes and organisational relationships and these processes and relationships need to be managed in line with the intended strategy, involving the effective coordination of information technology, people, finance and other business resources.

Companies that undertake successful business process redesign claim significant organisational improvements. This simply reflects the fact that many existing processes are less efficient than they could be and that new technology makes it possible to design more efficient processes. Strategic

planning and strategy implementation has to be subject to financial benchmarks. Financial analysis explicitly recognises this, reminding candidates of the importance of focusing on the key management accounting techniques that help to determine strategic action and the financial ratios and measures that may be used to assess the viability of a strategy and to monitor and measure its success.

Throughout, the syllabus recognises that successful strategic planning and implementation requires the effective recruitment, leadership, organisation and training and development of people.

DETAILED SYLLABUS

A Strategic position

1. The need for, and purpose of, strategic and business analysis
2. Environmental issues affecting the strategic position of an organisation
3. Competitive forces affecting an organisation
4. Marketing and the value of goods and services
5. The internal resources, capabilities and competences of an organisation
6. The expectations of stakeholders and the influence of ethics and culture

B Strategic choices

1. The influence of corporate strategy on an organisation
2. Alternative approaches to achieving competitive advantage
3. Alternative directions and methods of development

C Strategic action

1. Organising and enabling success
2. Managing strategic change
3. Understanding strategy development

D Business process change

1. The role of process and process change initiatives
2. Improving the processes of the organisation
3. Software solutions

E Information technology

1. Principles of e-business
2. E-business application: upstream supply chain management
3. E-business application: downstream supply chain management
4. E-business application: customer relationship management

F Project management

1. The nature of projects
2. Building a business case
3. Managing and leading projects
4. Planning, monitoring and controlling projects
5. Concluding a project

G Financial Analysis

1. The link between strategy and finance
2. Finance decisions to formulate and support business strategy
3. The role of cost and management accounting in strategic planning and implementation
4. Financial implications of making strategic choices and of implementing strategic actions

H People

1. Strategy and people: leadership
2. Strategy and people: job design

3. Strategy and people: staff development

APPROACH TO EXAMINING THE SYLLABUS

The syllabus is assessed by a three-hour paper-based examination.

Section A

Section A contains one multi-part question based on a case study scenario. This question is worth 50 marks.

Section B

Section B will consist of three discrete questions each worth 25 marks. Candidates must answer two questions from this section.

Total: 100 marks

Study Guide

A STRATEGIC POSITION

1. The need for, and purpose of, strategic and business analysis

- a) Recognise the fundamental nature and vocabulary of strategy and strategic decisions.^[2]
- b) Discuss how strategy may be formulated at different levels (corporate, business level, operational) of an organisation.^[2]
- c) Explore the Johnson, Scholes and Whittington model for defining elements of strategic management – the strategic position, strategic choices and strategy into action.^[3]
- d) Analyse how strategic management is affected by different organisational contexts.^[3]
- e) Compare three different strategy lenses (Johnson, Scholes and Whittington) for viewing and understanding strategy and strategic management.^[3]
- f) Explore the scope of business analysis and its relationship to strategy and strategic management in the context of the relational diagram of this syllabus.^[3]

2. Environmental issues affecting the strategic position of an organisation

- a) Assess the macro-environment of an organisation using PESTEL.^[3]
- b) Highlight the key drivers of change likely to affect the structure of a sector or market.^[3]
- c) Explore, using Porter's Diamond, the influence of national competitiveness on the strategic position of an organisation.^[2]
- d) Prepare scenarios reflecting different assumptions about the future environment of an organisation.^[3]
- e) Evaluate methods of business forecasting used when quantitatively assessing the likely outcome of different business strategies.^[3]

3. Competitive forces affecting an organisation

- a) Discuss the significance of industry, sector and convergence.^[3]
- b) Evaluate the sources of competition in an industry or sector using Porter's five forces framework.^[3]
- c) Assess the contribution of the lifecycle model, the cycle of competition and associated costing implications to understanding competitive behaviour.^[3]
- d) Analyse the influence of strategic groups and market segmentation.^[3]
- e) Determine the opportunities and threats posed by the environment of an organisation.^[2]

4. Marketing and the value of goods and services

- a) Analyse customers and markets^[2]
- b) Establish appropriate critical success factors (CSF) and key performance indicators (KPI) for products and services^[2]
- c) Explore the role of the value chain in creating and sustaining competitive advantage.^[2]
- d) Advise on the role and influence of value networks.^[3]
- e) Assess different approaches to benchmarking an organisation's performance.^[3]

5. The internal resources, capabilities and competences of an organisation

- a) Discriminate between strategic capability, threshold resources, threshold competences, unique resources and core competences.^[3]
- b) Discuss from a strategic perspective, the continuing need for effective cost management and control systems within organisations.^[3]
- c) Discuss the capabilities required to sustain competitive advantage.^[2]

d) Explain the impact of new product, process, and service developments and innovation in supporting business strategy.^[2]

e) Discuss the contribution of organisational knowledge to the strategic capability of an organisation.^[2]

f) Identify opportunities for managing the strategic capability of an organisation.^[2]

g) Determine the strengths and weaknesses of an organisation and formulate an appropriate SWOT analysis.^[2]

6. The expectations of stakeholders and the influence of ethics and culture

a) Advise on the implications of corporate governance on organisational purpose and strategy.^[2]

b) Evaluate, through stakeholder mapping, the relative influence of stakeholders on organisational purpose and strategy.^[3]

c) Assess ethical influences on organisational purpose and strategy.^[3]

d) Explore the scope of corporate social responsibility.^[3]

e) Assess the impact of culture on organisational purpose and strategy.^[3]

f) Prepare and evaluate a cultural web of an organisation.^[2]

g) Advise on how organisations can communicate their core values and mission.^[3]

B STRATEGIC CHOICES

1. The influence of corporate strategy on an organisation

a) Explore the relationship between a corporate parent and its business units.^[2]

b) Assess the opportunities and potential problems of pursuing different corporate strategies of product/market diversification from

a national, international and global perspective.^[3]

c) Assess the opportunities and potential problems of pursuing a corporate strategy of international diversity, international scale operations and globalisation.^[3]

d) Discuss a range of ways that the corporate parent can create and destroy organisational value.^[2]

e) Explain three corporate rationales for adding value – portfolio managers, synergy managers and parental developers.^[3]

f) Explain and assess a range of portfolio models (the growth/share (BCG) matrix, the public sector portfolio matrix, market attractiveness/SBU strength matrix, directional policy matrix, Ashridge Portfolio Display) that may assist corporate parents manage their business portfolios.^[3]

2. Alternative approaches to achieving competitive advantage

a) Evaluate, through the strategy clock, generic strategy options available to an organisation.^[3]

b) Advise on how price-based strategies, differentiation and lock-in can help an organisation sustain its competitive advantage.^[3]

c) Explore how organisations can respond to hypercompetitive conditions.^[2]

d) Assess opportunities for improving competitiveness through collaboration.^[3]

3. Alternative directions and methods of development

a) Determine generic development directions (employing an adapted Ansoff matrix and a TOWS matrix) available to an organisation.^[2]

b) Assess how internal development, mergers, acquisitions, strategic alliances and franchising can be used as different methods of pursuing a chosen strategic direction.^[3]

- c) Establish success criteria to assist in the choice of a strategic direction and method (strategic options).^[2]
- d) Assess the suitability of different strategic options to an organisation.^[3]
- e) Assess the feasibility of different strategic options to an organisation.^[3]
- f) Establish the acceptability of strategic options to an organisation through analysing risk and return on investment.^[3]

C STRATEGIC ACTION

1. Organising and enabling success

- a) Advise on how the organisation can be structured to deliver a selected strategy.^[3]
- b) Explore generic processes that take place within the structure, with particular emphasis on the planning process.^[3]
- c) Discuss how internal relationships can be organised to deliver a selected strategy.^[2]
- d) Discuss how external relationships (outsourcing, strategic alliances, networks and the virtual organisation) can be structured to deliver a selected strategy.^[2]
- e) Explore (through Mintzberg's organisational configurations) the design of structure, processes and relationships.^[3]

2. Managing strategic change

- a) Explore different types of strategic change and their implications.^[2]
- b) Determine and diagnose the organisational context of change using Balogun and Hope Hailey's contextual features model and the cultural web.^[3]
- c) Establish potential blockages and levers of change.^[2]
- d) Advise on the style of leadership appropriate to manage strategic change.^[2]

- e) Specify organisational roles required to manage strategic change.^[2]
- f) Discuss levers that can be employed to manage strategic change.^[2]

3. Understanding strategy development

- a) Discriminate between the concepts of intended and emergent strategies.^[3]
- b) Explain how organisations attempt to put an intended strategy into place.^[2]
- c) Highlight how emergent strategies appear from within an organisation.^[3]
- d) Discuss how process redesign, and e-business can contribute to emergent strategies.^[2]
- e) Assess the implications of strategic drift and the demand for multiple processes of strategy development.^[3]

D BUSINESS PROCESS CHANGE

1. The role of process and process change initiatives

- a) Advise on how an organisation can reconsider the design of its processes to deliver a selected strategy.^[3]
- b) Appraise business process change initiatives previously adopted by organisations.^[3]
- c) Establish an appropriate scope and focus for business process change using Harmon's process-strategy matrix.^[3]
- d) Explore the commoditisation of business processes.^[3]
- e) Advise on the implications of business process outsourcing.^[3]
- f) Recommend a business process redesign methodology for an organisation.^[2]

2. Improving the processes of the organisation

- a) Evaluate the effectiveness of current organisational processes.^[3]

- b) Describe a range of process redesign patterns.^[2]
- c) Establish possible redesign options for improving the current processes of an organisation.^[2]
- d) Assess the feasibility of possible redesign options.^[3]
- e) Assess the relationship between process redesign and strategy.^[3]

3. Software solutions

- a) Establish information system requirements required by business users.^[2]
- b) Assess the advantages and disadvantages of using a generic software solution to fulfil those requirements.^[2]
- c) Establish a process for evaluating, selecting and implementing a generic software solution.^[2]
- d) Explore the relationship between generic software solutions and business process redesign.^[2]

E INFORMATION TECHNOLOGY

1. Principles of e-business

- a) Discuss the meaning and scope of e-business.^[2]
- b) Advise on the reasons for the adoption of e-business and recognise barriers to its adoption.^[3]
- c) Evaluate how e-business changes the relationships between organisations and their customers.^[3]
- d) Discuss and evaluate the main business and marketplace models for delivering e-business.^[3]
- e) Advise on the hardware and software infrastructure required to support e-business.^[3]

- f) Advise on how the organisation can utilise information technology to help it deliver a selected strategy.^[3]

2. E-business application: upstream supply chain management

- a) Analyse the main elements of both the push and pull models of the supply chain.^[2]
- b) Discuss the relationship of the supply chain to the value chain and the value network.^[2]
- c) Assess the potential application of information technology to support and restructure the supply chain.^[3]
- d) Advise on how external relationships with suppliers and distributors can be structured to deliver a restructured supply chain.^[3]
- e) Discuss the methods, benefits and risks of e-procurement.^[2]
- f) Assess different options and models for implementing e-procurement.^[2]

3. E-business application: downstream supply chain management

- a) Define the scope and media of e-marketing.^[2]
- b) Highlight how the media of e-marketing can be used when developing an effective e-marketing plan.^[2]
- c) Explore the characteristics of the media of e-marketing using the '6I's of Interactivity, Intelligence, Individualisation, Integration, Industry structure and Independence of location.^[2]
- d) Evaluate the effect of the media of e-marketing on the traditional marketing mix of product, promotion, price, place, people, processes and physical evidence.^[3]
- e) Describe a process for establishing a pricing strategy for products and services that recognises both economic and non-economic factors.^[2]

- f) Assess the importance of on-line branding in e-marketing and compare it with traditional branding.^[2]

4. E-business application: customer relationship management

- a) Define the meaning and scope of customer relationship management.^[2]
- b) Explore different methods of acquiring customers through exploiting electronic media.^[2]
- c) Evaluate different buyer behaviour amongst on-line customers.^[3]
- d) Recommend techniques for retaining customers using electronic media.^[2]
- e) Recommend how electronic media may be used to increase the activity and value of established, retained customers.^[2]
- f) Discuss the scope of a representative software package solution designed to support customer relationship management.^[2]

F PROJECT MANAGEMENT

1. The nature of projects

- a) Determine the distinguishing features of projects and the constraints they operate in.^[2]
- b) Discuss the implications of the triple constraint of scope, time and cost.^[2]
- c) Discuss the relationship between organisational strategy and project management.^[2]
- d) Identify and plan to manage risks.^[2]
- e) Advise on the structures and information that have to be in place to successfully initiate a project.^[3]
- f) Explain the relevance of projects to process re-design and e-business systems development.^[2]

2. Building the business case

- a) Describe the structure and contents of a business case document.^[2]
- b) Analyse, describe, assess and classify benefits of a project investment.^[3]
- c) Analyse, describe, assess and classify the costs of a project investment.^[3]
- d) Evaluate the costs and benefits of a business case using standard techniques
- e) Establish responsibility for the delivery of benefits.^[2]
- f) Explain the role of a benefits realisation plan.^[2]

3. Managing and leading projects

- a) Discuss the organisation and implications of project-based team structures.^[2]
- b) Establish the role and responsibilities of the project manager and the project sponsor.^[2]
- c) Identify and describe typical problems encountered by a project manager when leading a project.^[2]
- d) Advise on how these typical problems might be addressed and overcome.^[3]

4. Planning, monitoring and controlling projects

- a) Discuss the principles of a product breakdown structure.^[2]
- b) Assess the importance of developing a project plan and discuss the work required to produce this plan.^[3]
- c) Monitor the status of a project and identify project risks, issues, slippage and changes.^[2]
- d) Formulate responses for dealing with project risks, issues, slippage and changes.^[2]
- e) Discuss the role of benefits management and project gateways in project monitoring.^[2]

5. Concluding a project

- a) Establish mechanisms for successfully concluding a project.^[2]
- b) Discuss the relative meaning and benefits of a post-implementation and a post-project review.^[2]
- c) Discuss the meaning and value of benefits realisation.^[2]
- d) Evaluate how project management software may support the planning and monitoring of a project.^[3]
- e) Apply 'lessons learned' to future business case validation and to capital allocation decisions.^[3]

G FINANCIAL ANALYSIS

1. The link between strategy and finance

- a) Explain the relationship between strategy and finance^[3]
 - i) Managing for value
 - ii) Financial expectations of stakeholders
 - iii) Funding strategies

2. Finance decisions to formulate and support business strategy

- a) Determine the overall investment requirements of the business.^[2]
- b) Evaluate alternative sources of finance for these investments and their associated risks.^[3]
- c) Efficiently and effectively manage the current and non-current assets of the business from a finance and risk perspective.^[2]

3. The role of cost and management accounting in strategic planning and decision-making

- a) Explain the role, advantages and possible limitations of a budgetary process.^[2]
- b) Explain the principles of standard costing, its role in variance analysis and suggest possible reasons for identified variances.^[3]

- c) Evaluate strategic and operational decisions taking into account risk and uncertainty using decision trees.^[3]

- d) Evaluate the following strategic options using marginal and relevant costing techniques.^[3]
 - i) Make or buy decisions
 - ii) Accepting or declining special contracts
 - iii) Closure or continuation decisions
 - iv) Effective use of scarce resources

4. Financial implications of making strategic choices and of implementing strategic actions

- a) Apply efficiency ratios to assess how efficiently an organisation uses its current resources.^[2]
- b) Apply appropriate gearing ratios to assess the risks associated with financing and investment in the organisation.^[2]
- c) Apply appropriate liquidity ratios to assess the organisation's short-term commitments to creditors and employees.^[2]
- d) Apply appropriate profitability ratios to assess the viability of chosen strategies.^[2]
- e) Apply appropriate investment ratios to assist investors and shareholders in evaluating organisational performance and strategy.^[2]

H PEOPLE

1. Strategy and people: leadership

- a) Explain the role of visionary leadership and identify the key leadership traits effective in the successful formulation and implementation of strategy and change management.^[3]
- b) Apply and compare alternative classical and modern theories of leadership in the effective implementation of strategic objectives.^[3]

2. Strategy and people: job design

- a) Assess the contribution of four different approaches to job design (scientific management, job enrichment, Japanese management and re-engineering).^[3]

- b) Explain the human resource implications of knowledge work and post-industrial job design.^[2]
- c) Discuss the tensions and potential ethical issues related to job design.^[2]
- d) Advise on the relationship of job design to process re-design, project management and the harnessing of e-business opportunities.^[3]

3. Strategy and people: staff development

- a) Discuss the emergence and scope of human resource development, succession planning and their relationship to the strategy of the organisation.^[2]
- b) Advise and suggest different methods of establishing human resource development.^[3]
- c) Advise on the contribution of competency frameworks to human resource development.^[3]
- d) Discuss the meaning and contribution of workplace learning, the learning organisation, organisation learning and knowledge management.^[3]

**NOTE OF SIGNIFICANT CHANGES TO STUDY
GUIDE PAPER P3**

ACCA periodically reviews its qualification syllabuses so that they fully meet the needs of stakeholders including employers, students, regulatory and advisory bodies and learning providers.

There are no changes to the syllabus.