

# Corporate and Business Law (VNM) (F4) June & December 2012

This syllabus and study guide is designed to help with planning study and to provide detailed information on what could be assessed in any examination session.

## THE STRUCTURE OF THE SYLLABUS AND STUDY GUIDE

### Relational diagram of paper with other papers

This diagram shows direct and indirect links between this paper and other papers preceding or following it. Some papers are directly underpinned by other papers such as Advanced Performance Management by Performance Management. These links are shown as solid line arrows. Other papers only have indirect relationships with each other such as links existing between the accounting and auditing papers. The links between these are shown as dotted line arrows. This diagram indicates where you are expected to have underpinning knowledge and where it would be useful to review previous learning before undertaking study.

### Overall aim of the syllabus

This explains briefly the overall objective of the paper and indicates in the broadest sense the capabilities to be developed within the paper.

### Main capabilities

This paper's aim is broken down into several main capabilities which divide the syllabus and study guide into discrete sections.

### Relational diagram of the main capabilities

This diagram illustrates the flows and links between the main capabilities (sections) of the syllabus and should be used as an aid to planning teaching and learning in a structured way.

### Syllabus rationale

This is a narrative explaining how the syllabus is structured and how the main capabilities are linked. The rationale also explains in further detail what the examination intends to assess and why.

### Detailed syllabus

This shows the breakdown of the main capabilities (sections) of the syllabus into subject areas. This is the blueprint for the detailed study guide.

### Approach to examining the syllabus

This section briefly explains the structure of the examination and how it is assessed.

### Study Guide

This is the main document that students, tuition providers and publishers should use as the basis of their studies, instruction and materials. Examinations will be based on the detail of the study guide which comprehensively identifies what could be assessed in any examination session. The study guide is a precise reflection and breakdown of the syllabus. It is divided into sections based on the main capabilities identified in the syllabus. These sections are divided into subject areas which relate to the sub-capabilities included in the detailed syllabus. Subject areas are broken down into sub-headings which describe the detailed outcomes that could be assessed in examinations. These outcomes are described using verbs indicating what exams may require students to demonstrate, and the broad intellectual level at which these may need to be demonstrated (\*see intellectual levels below).

### Learning Materials

ACCA's Approved Learning Partner - content (ALP-c) is the programme through which ACCA approves learning materials from high quality content providers designed to support study towards ACCA's qualifications.

ACCA has one Platinum Approved Learning Partner - content which is BPP Learning Media. In addition, there are a number of Gold Approved Learning Partners - content. For information about ACCA's Approved Learning Partners - content,

please go ACCA's Content Provider Directory.

At present, there are no approved learning materials for this paper. ACCA is working with its Approved Learning Partners - content to provide these. For the most up to date information on subscribers to the Directory who may provide useful materials, although these will not have been Quality Assured by ACCA, please go to ACCA's Content Provider Directory. You will also find details here of any other learning materials which the Examiner has suggested may be useful for students.

ACCA's Content Provider Directory can be found here –  
[http://www.accaglobal.com/learningproviders/alpc/content\\_provider\\_directory/search/](http://www.accaglobal.com/learningproviders/alpc/content_provider_directory/search/).

Relevant articles will also be published in Student Accountant.

## INTELLECTUAL LEVELS

The syllabus is designed to progressively broaden and deepen the knowledge, skills and professional values demonstrated by the student on their way through the qualification.

The specific capabilities within the detailed syllabuses and study guides are assessed at one of three intellectual or cognitive levels:

- Level 1: Knowledge and comprehension
- Level 2: Application and analysis
- Level 3: Synthesis and evaluation

Very broadly, these intellectual levels relate to the three cognitive levels at which the Knowledge module, the Skills module and the Professional level are assessed.

Each subject area in the detailed study guide included in this document is given a 1, 2, or 3 superscript, denoting intellectual level, marked at the end of each relevant line. This gives an indication of the intellectual depth at which an area could be assessed within the examination. However, while level 1 broadly equates with the Knowledge module, level 2 equates to the Skills module and level 3 to the Professional level, some lower level skills can continue to be assessed as the student progresses through each module and level. This reflects that at each stage of study there will be a

requirement to broaden, as well as deepen capabilities. It is also possible that occasionally some higher level capabilities may be assessed at lower levels.

## LEARNING HOURS

The ACCA qualification does not prescribe or recommend any particular number of learning hours for examinations because study and learning patterns and styles vary greatly between people and organisations. This also recognises the wide diversity of personal, professional and educational circumstances in which ACCA students find themselves.

Each syllabus contains between 23 and 35 main subject area headings depending on the nature of the subject and how these areas have been broken down.

## GUIDE TO EXAM STRUCTURE

The structure of examinations varies within and between modules and levels.

The Fundamentals level examinations contain 100% compulsory questions to encourage candidates to study across the breadth of each syllabus.

The Knowledge module is assessed by equivalent two-hour paper based and computer based examinations.

The Skills module examinations are all paper based three-hour papers. The structure of papers varies from ten questions in the *Corporate and Business Law* (F4) paper to four 25 mark questions in *Financial Management* (F9). Individual questions within all Skills module papers will attract between 10 and 30 marks.

The Professional level papers are all three-hour paper based examinations, all containing two sections. Section A is compulsory, but there will be some choice offered in Section B.

For all three hour examination papers, ACCA has introduced 15 minutes reading and planning time.

This additional time is allowed at the beginning of each three-hour examination to allow candidates to

read the questions and to begin planning their answers before they start writing in their answer books. This time should be used to ensure that all the information and exam requirements are properly read and understood.

During reading and planning time candidates may only annotate their question paper. They may not write anything in their answer booklets until told to do so by the invigilator.

The Essentials module papers all have a Section A containing a major case study question with all requirements totalling 50 marks relating to this case. Section B gives students a choice of two from three 25 mark questions.

Section A of each of the Options papers contains 50-70 compulsory marks from two questions, each attracting between 25 and 40 marks. Section B will offer a choice of two from three questions totalling 30-50 marks, with each question attracting between 15 and 25 marks.

The pass mark for all ACCA Qualification examination papers is 50%.

## GUIDE TO EXAMINATION ASSESSMENT

ACCA reserves the right to examine anything contained within the study guide at any examination session. This includes knowledge, techniques, principles, theories, and concepts as specified.

For the financial accounting, audit and assurance, law and tax papers except where indicated otherwise, ACCA will publish *examinable documents* once a year to indicate exactly what regulations and legislation could potentially be assessed within identified examination sessions..

For paper based examinations regulation **issued** or legislation **passed** on or before 30<sup>th</sup> September annually, will be assessed from June 1<sup>st</sup> of the following year to May 31<sup>st</sup> of the year after. Please refer to the examinable documents for the paper (where relevant) for further information.

Regulation issued or legislation passed in accordance with the above dates may be examinable even if the **effective** date is in the future.

The term issued or passed relates to when regulation or legislation has been formally approved. The term effective relates to when regulation or legislation must be applied to an entity transactions and business practices.

The study guide offers more detailed guidance on the depth and level at which the examinable documents will be examined. The study guide should therefore be read in conjunction with the examinable documents list.

# Syllabus

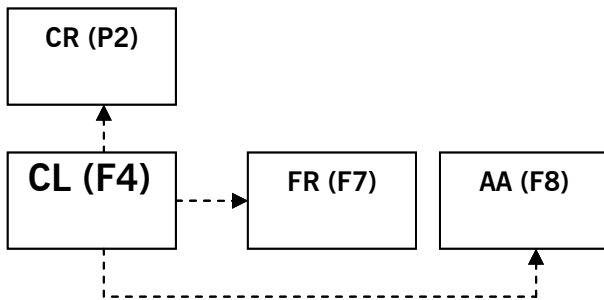

## AIM

To develop knowledge and skills in the understanding of the general legal framework, and of specific legal areas relating to business, recognising the need to seek further specialist legal advice where necessary.

## MAIN CAPABILITIES

On successful completion of this paper candidates should be able to:

- A** Identify the essential elements of the legal system, including the main sources of law
- B** Recognise and apply the appropriate legal rules relating to the law of obligations
- C** Explain and apply the law relating to employment relationships
- D** Distinguish between alternative forms and constitutions of business organisations
- E** Recognise and compare types of capital and the financing of companies
- F** Describe and explain how companies are managed and administered
- G** Recognise the legal implications relating to companies in difficulty or in crisis
- H** Demonstrate an understanding of governance and ethical issues relating to business.

## RELATIONAL DIAGRAM OF MAIN CAPABILITIES

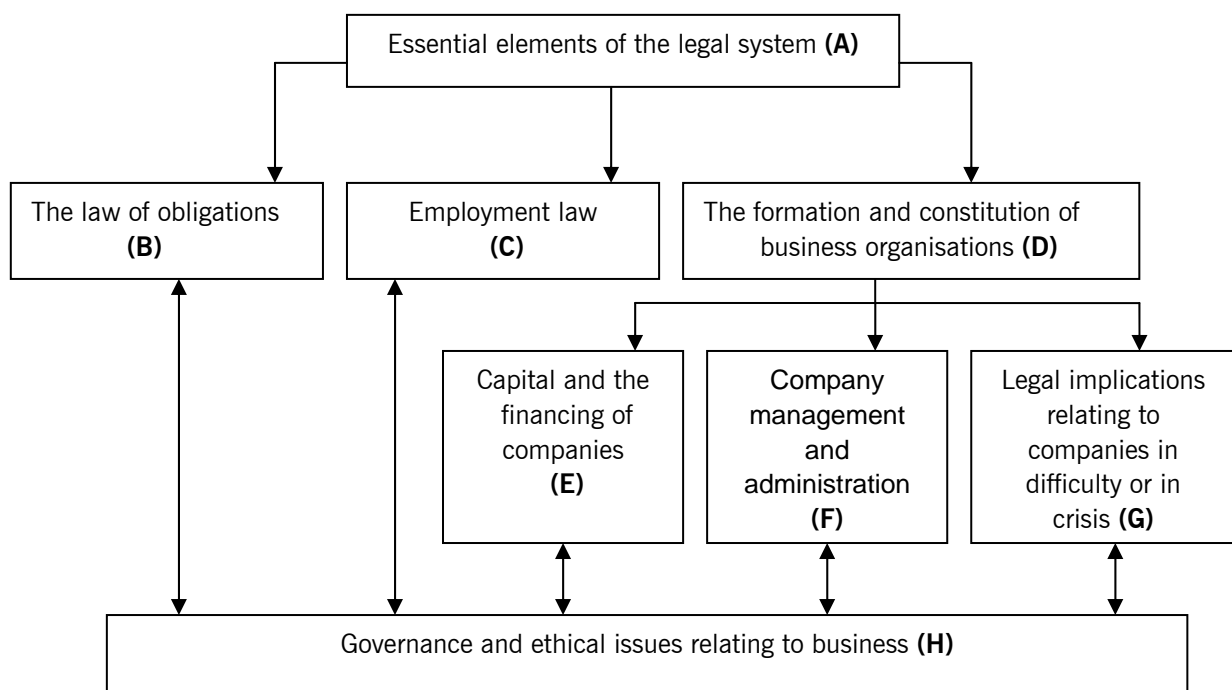

## **RATIONALE**

*Corporate and Business Law* is divided into eight areas. The syllabus starts with an introduction to the overall legal system of the Socialist Republic of Vietnam such as the sources of law and the court system. It then leads into the area of the law of obligations including contract and tort, which underpin entrepreneurial activity and business transactions generally.

The syllabus then covers a range of specific legal areas relating to various aspects of business of most concern to financial professionals. These are the law relating to employment and the law relating to companies. These laws include the formation and constitution of companies, the financing of companies and types of capital, and the day-to-day management, the administration and regulation of companies and legal aspects of companies facing difficulty or in crisis.

The final section links back to all the previous areas. This section deals with corporate governance, ethics and ethical behaviour relating to businesses, including criminal law.

## **DETAILED SYLLABUS**

### **A Essential elements of the legal system**

1. Sources of law
2. Court structure
3. Constitutional rights

### **B The law of obligations**

1. Formation of contract
2. Content of contracts
3. Means of securing obligations
4. Breach of contract and consequences
5. Non-contractual obligations

### **C Employment law**

1. Labour agreements

2. Dismissal

### **D The formation and constitution of business organisations**

1. Partnerships
2. Companies and legal personality
3. Company formation
4. Voluntary representation

### **E Capital and the financing of companies**

1. Share capital
2. Loan capital
3. Capital maintenance and dividend law

### **F Company management and administration**

1. Members' Council, board of management and company directors
2. Other management bodies
3. Company meetings and decision taking

### **G Legal implications relating to companies in difficulty or in crisis**

1. Insolvency

### **H Governance and ethical issues relating to business**

1. Corporate governance
2. Compliance and fraudulent behaviour

## **APPROACH TO EXAMINING THE SYLLABUS**

The syllabus is assessed by a three hour paper-based examination.

The examination consists of seven 10 mark questions assessing knowledge of the law, and three 10 mark application questions.

## **NOTE ON CASE LAW**

Candidates should support their answers with analysis referring to cases or examples. There is no need to detail the facts of the case. Remember, it is the point of law that the case establishes that is important, although knowing the facts of cases can be helpful as sometimes questions include scenarios based on well-known cases. Further it is not necessary to quote section numbers of Acts.

# Study Guide

## **A ESSENTIAL ELEMENTS OF THE LEGAL SYSTEM**

### **1. Sources of law**

- a) Define law and distinguish types of law.<sup>[1]</sup>
- b) Explain the purpose and significance of the Constitution.<sup>[1]</sup>
- c) Explain legislation and the different forms it may take, including national laws and laws enacted by bodies subordinate to the government.<sup>[2]</sup>

### **2. Court structure**

- a) Explain the structure of the courts.<sup>[1]</sup>
- b) Explain the roles of the courts and their jurisdictions.<sup>[1]</sup>

### **3. Constitutional rights**

- a) Explain the rights and legal capacity of citizens and legal entities under the Civil Code.<sup>[2]</sup>
- b) Explain the limitations that may apply to the legal capacity of individuals.<sup>[1]</sup>

## **B THE LAW OF OBLIGATIONS**

### **1. Formation of contract**

- a) Define a contract.<sup>[1]</sup>
- b) Distinguish a contract from other forms of communication, including advertisements and supply of information.<sup>[2]</sup>

### **2. Content of contracts**

- a) Explain the essential elements of a contract.<sup>[2]</sup>
- b) Distinguish between the types of contract set out in the Civil Code.<sup>[1]</sup>

### **3. Means of securing obligations**

- a) Explain how the Civil Code enables obligations to be secured.<sup>[2]</sup>

- b) Explain the methods by which obligations may be secured.<sup>[2]</sup>

## **4. Breach of contract and consequences**

- a) Explain the meaning of breach of contract.<sup>[2]</sup>
- b) Explain the consequences of a breach of contract.<sup>[2]</sup>

## **5. Non-contractual obligations**

- a) Define tort.<sup>[1]</sup>
- b) Explain how obligations in tort arise.<sup>[2]</sup>
- c) Discuss the consequences of damage or loss in relation to non-contractual obligations.<sup>[2]</sup>

## **C EMPLOYMENT LAW**

### **1. Labour agreements**

- a) Distinguish between the employed and individual entrepreneurs.<sup>[2]</sup>
- b) Explain the nature of a labour agreement and give examples of the main duties placed on the parties to such a contract.<sup>[2]</sup>

### **2. Dismissal**

- a) Explain the grounds and conditions for dismissal.<sup>[1]</sup>
- b) Discuss the rights and obligations of employers and employees when an employee is dismissed.<sup>[2]</sup>

## **D THE FORMATION AND CONSTITUTION OF BUSINESS ORGANISATIONS**

### **1. Partnerships**

- a) Demonstrate a knowledge of the legislation governing partnerships.<sup>[1]</sup>
- b) Explain the different types of partnership that may be formed.<sup>[2]</sup>
- c) Explain how partnerships are formed.<sup>[1]</sup>

- d) Explain the authority of partners in relation to partnership activity.<sup>[2]</sup>
- e) Analyse the liability of various partners for partnership debts.<sup>[2]</sup>
- f) Explain the ways in which partnerships can be brought to an end.<sup>[2]</sup>

## **2. Companies and legal personality**

- a) Distinguish between individual entrepreneurs, partnerships and companies.<sup>[2]</sup>
- b) Explain the meaning and effect of limited liability.<sup>[2]</sup>
- c) Analyse different types of company, especially limited liability companies and shareholding companies.<sup>[2]</sup>
- d) Illustrate the effects of separate personality.<sup>[2]</sup>
- e) Recognise instances where separate personality will be ignored.<sup>[2]</sup>

## **3. Company formation**

- a) Explain the procedure for registering different types of limited company.<sup>[2]</sup>
- b) Explain the capital requirements for establishing different types of company.<sup>[1]</sup>
- c) Explain the content and effect of the company's constitutional documents.<sup>[2]</sup>

## **4. Voluntary representation**

- a) Explain the forms of voluntary representation permitted by the Civil Code.<sup>[2]</sup>
- b) Explain power of attorney and the provisions of the Civil Code in relation to executing a valid power of attorney.<sup>[1]</sup>

## **E CAPITAL AND THE FINANCING OF COMPANIES**

### **1. Share capital**

- a) Examine the different meanings of capital.<sup>[2]</sup>

- b) Illustrate the differences between ordinary shares and preference shares.<sup>[2]</sup>

- c) Explain the rights of shareholders.<sup>[2]</sup>

### **2. Loan capital**

- a) Distinguish loan capital from share capital.<sup>[2]</sup>
- b) Explain the rights of those who provide long-term capital.<sup>[2]</sup>

### **3. Capital maintenance and dividend law**

- a) Explain the legal provisions applicable to increasing and reducing share capital.<sup>[2]</sup>
- b) Explain the consequences of increasing and reducing share capital.<sup>[2]</sup>
- c) Explain the rules governing the distribution of a dividend.<sup>[2]</sup>

## **F COMPANY MANAGEMENT AND ADMINISTRATION**

### **1. Members' Council, board of management and company directors**

- a) Explain the role of the Members' Council, Chairman of the Members' Council, board of management and the director or general director in the operation of a company.<sup>[2]</sup>
- b) Distinguish between the powers of the management bodies of the company and the shareholders.<sup>[2]</sup>
- c) Explain the matters that fall within the exclusive competence of the management bodies of the company and the shareholders.<sup>[2]</sup>

### **2. Other management bodies**

- a) Discuss the appointment procedure relating to, and the duties and powers of, a company's external auditors.<sup>[2]</sup>
- b) Discuss the appointment procedure relating to, and the duties and powers of, a company's Inspection Committee.<sup>[2]</sup>

### **3. Company meetings and decision taking**

- a) Explain the legal requirements in relation to meetings of shareholders.<sup>[1]</sup>
- b) Explain the procedure for calling such meetings.<sup>[1]</sup>
- c) Detail the procedure for conducting meetings.<sup>[1]</sup>
- d) Explain how decisions are made at meetings, including voting procedures and protocols.<sup>[2]</sup>

## **G LEGAL IMPLICATIONS RELATING TO COMPANIES IN DIFFICULTY OR IN CRISIS**

### **1. Insolvency**

- a) Define the meaning of insolvency.<sup>[1]</sup>
- b) Discuss the criteria applied to establish insolvency.<sup>[2]</sup>
- c) Explain the jurisdiction of the courts and the duties and powers of judges in relation to the insolvency of enterprises.<sup>[2]</sup>
- d) Explain the duties, powers and responsibilities of the committee for management and liquidation of assets.<sup>[2]</sup>
- e) Explain the insolvency process and the roles the parties involved in this process.<sup>[2]</sup>

## **H GOVERNANCE AND ETHICAL ISSUES RELATING TO BUSINESS**

### **1. Corporate governance**

- a) Explain the idea of corporate governance.<sup>[2]</sup>
- b) Identify and explain the legal regulation of corporate governance.<sup>[2]</sup>

### **2. Compliance and fraudulent behaviour**

- a) Explain the legal obligations of companies in relation to disclosure of information.<sup>[2]</sup>
- b) Recognise the nature and legal control over activities that may destabilise securities markets.<sup>[2]</sup>